

Technical Specifications – WPOZ 0250

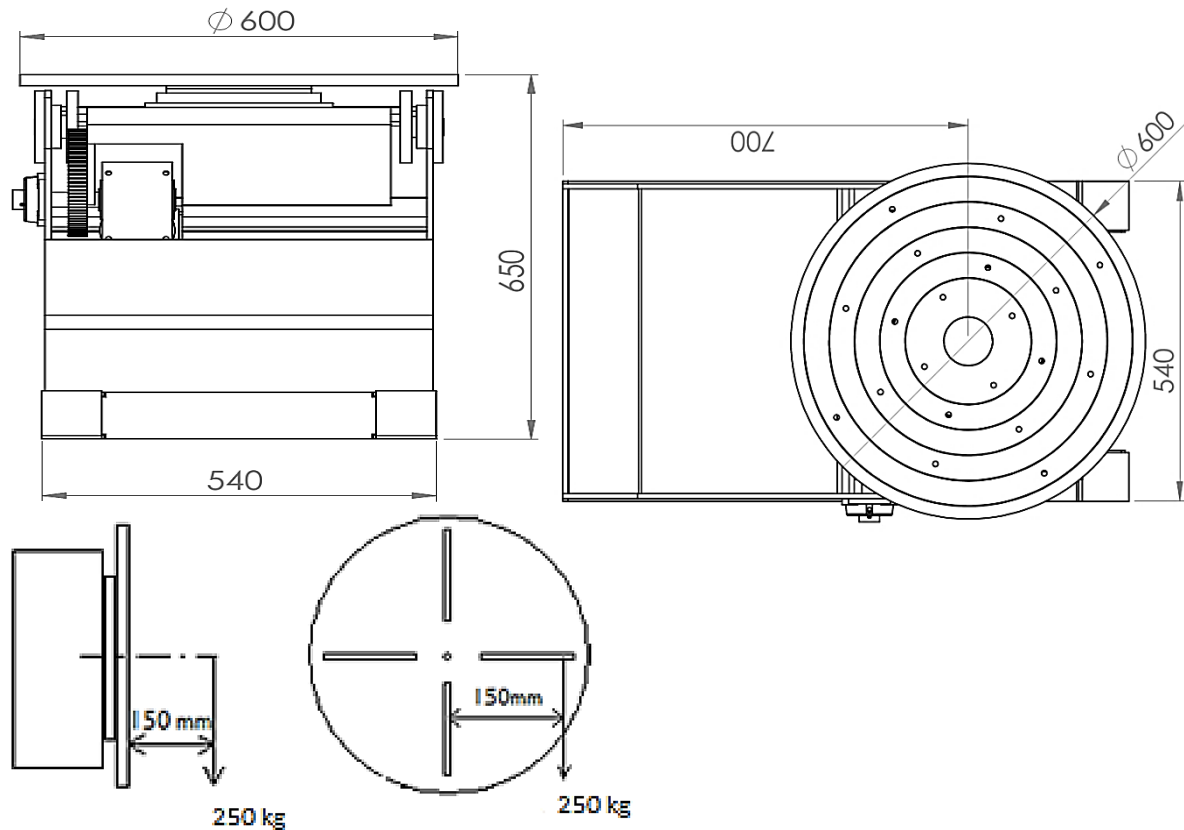

Max. Load (N)	2500
Axis Eccentricity	150mm for Rotation and Tilting
Rotation Speed (rpm/min)	Min 0,4 – Max 4 at 5 Hz – 50 Hz Range
Rotation Torque (kg.m)	
Rotation Motor	1 x .. Kw AC Motor
Tilting Angle	120°
Tilting Speed from 0 to 120	30 second
Tilting Torque (kg.m)	
Tilting Motor	1 x .. Kw AC Motor
Driver	1 x 0,55 kW
Face Plate Diameter	600 mm
Fixing Slots	M10 Holes
Control Device	Hand Pendant
Incoming Supply	380/400V, 3Ph, 50Hz @ 5 – 50 Hz
Applicable Optional	Foot Pedal
Colour	RAL5018 – TURQUOISERAL9005 – BLACK / Texture Painting
Welding Torch Holder	Yes
Shipping Dimension & Weight	Width 900mm x Length 1300mm x Height 1000mm / 250 Kg